

Warranty, Service & Repair

To register your product with the manufacturer, fill out the enclosed warranty card and return it immediately to:

Flowline Inc.
10500 Humbolt Street
Los Alamitos, CA 90720.

If for some reason your product must be returned for factory service, contact Flowline Inc. to receive a Material Return Authorization number (MRA) first, providing the following information:

1. Part Number, Serial Number
2. Name and telephone number of someone who can answer technical questions related to the product and its application.
3. Return Shipping Address
4. Brief Description of the Symptom
5. Brief Description of the Application

Once you have received a Material Return Authorization number, ship the product prepaid in its original packing to:

Flowline Factory Service
MRA _____
10500 Humbolt Street
Los Alamitos, CA 90720

To avoid delays in processing your repair, write the MRA on the shipping label. Please include the information about the malfunction with your product. This information enables our service technicians to process your repair order as quickly as possible.

FLOWLINE®

Float-Point™ High-Temp Vertical Level Switch AV16, AV26, AV36 & AV46 Series Owner's Manual



Version 1.1A

© 2002 FLOWLINE Inc.

All rights reserved.

Manual # LV900004

05/05

WARRANTY

Flowline warrants to the original purchaser of its products that such products will be free from defects in material and workmanship under normal use and service for a period which is equal to the shorter of one year from the date of purchase of such products or two years from the date of manufacture of such products.

This warranty covers only those components of the products which are non-moving and not subject to normal wear. Moreover, products which are modified or altered, and electrical cables which are cut to length during installation are not covered by this warranty.

Flowline's obligation under this warranty is solely and exclusively limited to the repair or replacement, at Flowline's option, of the products (or components thereof) which Flowline's examination proves to its satisfaction to be defective. FLOWLINE SHALL HAVE NO OBLIGATION FOR CONSEQUENTIAL DAMAGES TO PERSONAL OR REAL PROPERTY, OR FOR INJURY TO ANY PERSON.

This warranty does not apply to products which have been subject to electrical or chemical damage due to improper use, accident, negligence, abuse or misuse. Abuse shall be assumed when indicated by electrical damage to relays, reed switches or other components. The warranty does not apply to products which are damaged during shipment back to Flowline's factory or designated service center or are returned without the original casing on the products. Moreover, this warranty becomes immediately null and void if anyone other than service personnel authorized by Flowline attempts to repair the defective products.

Products which are thought to be defective must be shipped prepaid and insured to Flowline's factory or a designated service center (the identity and address of which will be provided upon request) within 30 days of the discovery of the defect. Such defective products must be accompanied by proof of the date of purchase.

Flowline further reserves the right to unilaterally waive this warranty and to dispose of any product returned to Flowline where:

- a. There is evidence of a potentially hazardous material present with product.
- b. The product has remained unclaimed at Flowline for longer than 30 days after dutifully requesting disposition of the product.

THERE ARE NO WARRANTIES WHICH EXTEND BEYOND THE DESCRIPTION ON THE FACE OF THIS WARRANTY. This warranty and the obligations and liabilities of Flowline under it are exclusive and instead of, and the original purchaser hereby waives, all other remedies, warranties, guarantees or liabilities, express or implied. EXCLUDED FROM THIS WARRANTY IS THE IMPLIED WARRANTY OF FITNESS OF THE PRODUCTS FOR A PARTICULAR PURPOSE OR USE AND THE IMPLIED WARRANTY OF MERCHANTABILITY OF THE PRODUCTS.

This warranty may not be extended, altered or varied except by a written instrument signed by a duly-authorized officer of Flowline, Inc.

SPECIFICATIONS

Step One

Length: 4" to 72"(10 cm to 1.8m)
 Switch points: 1 to 4 (set by factory)
 Accuracy: ± 3 mm in water
 Repeatability: ± 1 mm in water
 Specific gravity: 0.75 minimum
 Orientation: ± 30° vertical
 Contact type: (1-4) SPDT reed
 Contact rating: 240 VAC/VDC @ 20 VA
 Process temp.: F: -40° to 300°
 C: -40° to 148.9°
 Pressure: 750 psi max.
 51.7 bar max.
 Guide/float mat.: 316 ss
 Process mount: 2" NPT
 Enclosure rating: S443: NEMA 4X (IP65)
 S453: NEMA 7 (IP65)
 Installed height: S443: 5.2" (13.2 cm)
 S453: 6.2" (15.7 cm)
 Encl. material: S443: PP, UL94VO
 S453: Aluminum
 Conduit entrance: Single, 1/2" NPT
 Wire type: 3 - 12 wires, #18 AWG
 Termination: 3-12 poles, terminal strip
 Classification: S443: General purpose
 S453: Explosion proof
 Approvals: S453: FM, CSA:
 (S453 only) Class I, Division I, Groups B, C & D;
 Class II, Groups E, F and G
 CE compliance: EN 50082-2 immunity
 EN 55011 emission
 EN 61010-1 safety

Technology

The Float-Point with Compact Junction Box consists of 1 to 4 floats with internal magnets and reed switches installed within the shaft. When the level is below the float, it rest on a grip ring such that the magnet does not influence the reed switch. As the float becomes immersed in liquid, the float becomes buoyant and the magnet elevates causing the reed switch to change its state. Each reed switch is rated for 20 VA applications. Please review the chart above for the maximum resistive load on the 20 VA reed switch.

Reed Switch Rating		Max. Resistive Load	
VA	Volts	Amps AC	Amps DC
20	0-30	0.4	0.3
	120	0.17	0.13
	240	0.08	0.06

Wiring Color Chart

Each level switch features a base color to distinguish itself from the other switch points. The base color also indicates the Common Wire for the reed switch. The Normally Open Wire for the reed switch is designated with a White wire and a stripe of the base color. The Normally Closed Wire for the reed switch is designated with a White wire with a Black stripe and a stripe of the base color. Use the chart below to identify the correct wiring for the switch points.

Switch	COM	NO	NC
B	Red	Wh/Red	Wh/Blk/Red
C	Yellow	Wh/Yellow	Wh/Blk/Yellow
D	Blue	Wh/Blue	Wh/Blk/Blue
E	Brown	Wh/Brown	Wh/Blk/Brown

Dimensions:

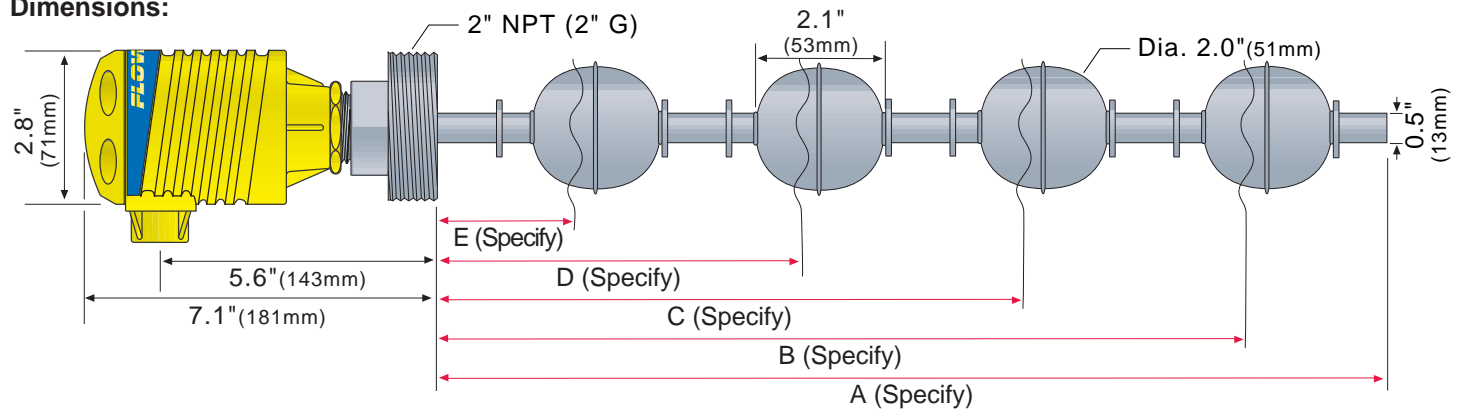

Junction Box:

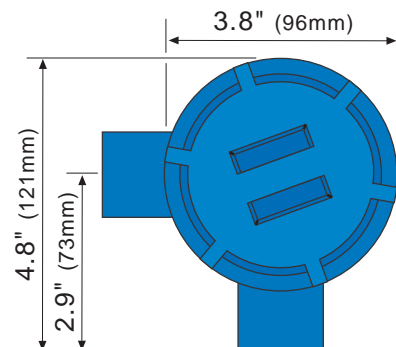

SAFETY PRECAUTIONS

Step Two

⚠ About this Manual:

PLEASE READ THE ENTIRE MANUAL PRIOR TO INSTALLING OR USING THIS PRODUCT. This manual includes information on the Float-Point Vertical Level Switches, models AV16-S4_3, AV26-S4_3, AV36-S4_3 & AV46-S4_3. Please refer to the part number located on the sensor label to verify the exact model which you have purchased.

⚠ User's Responsibility for Safety:

FLOWLINE manufactures a wide range of liquid level switches and technologies. While each of these switches are designed to operate in a wide variety of applications, it is the user's responsibility to select a switch model that is appropriate for the application, install it properly, perform tests of the installed system, and maintain all components. The failure to do so could result in property damage or serious injury.

⚠ Proper Installation and Handling:

Because this is an electrically operated device, only properly trained staff should install and/or repair this product. Use a proper sealant with all installations. Never over-tighten the sensor within the fitting, beyond a maximum of 80 inch-pounds torque. Always check for leaks prior to system start-up.

⚠ Material Compatibility:

The wetted portion of the Float-Point is available in 316 Stainless Steel. The junction box is made of either Polypropylene (PP) for the AV_6-S443 or Aluminum for the AV_6-S453. Make sure that the switch is compatible with the application liquids. To determine the chemical compatibility between the sensor and its application liquids, refer to the Compass Corrosion Guide, available from Compass Publications (858-589-9636).

⚠ Temperature and Pressure:

The AV_6 series is designed for use in application temperatures up to 300 °F (148.9 °C), and for use at pressures up to 750 psi (51.7 bar).

⚠ Wiring and Electrical:

The supply voltage used for the AV_6 series switch should never exceed 240 VAC/VDC @ 20 VA. Electrical wiring of the switch should be performed in accordance with all applicable national, state, and local codes.

⚠ Flammable, Explosive and Hazardous Applications:

The AV_6-S443 series switch should not be used within flammable or explosive applications. Only use the AV_6-S453 series in hazardous locations when properly connected to an approved control device. In hazardous applications, use redundant measurement and control points, each having a different sensing technology. Refer to the National Electrical Code (NEC) for all applicable installation requirements in hazardous locations.

INSTALLATION

Step Three

Float-Point Installation:

FLOWLINE's Float-Point level switch is an in tank system. Float-Point may be installed through the top wall of any tank or flange, using a standard 2" NPT tank adapter or blind flange. If the top is not available, Flowline's side mount bracket, LM50-1001, enables Float-Point to be installed directly to the side wall or lip of the tank.

Tank Adapter:

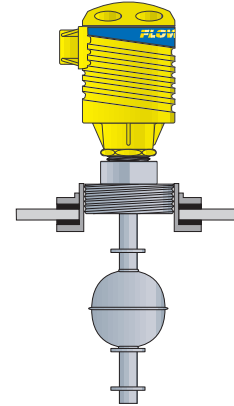

Flange Mounting:

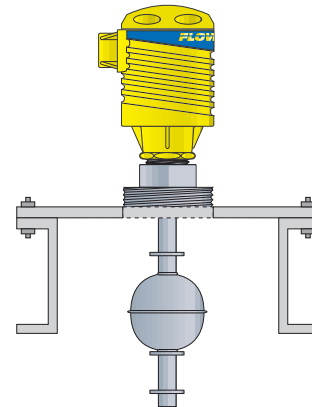

Side Mount Bracket:

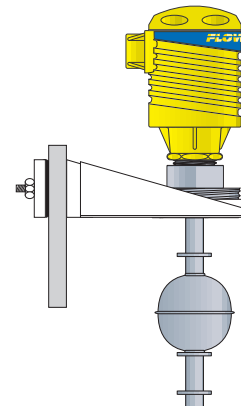

Lip of Tank:

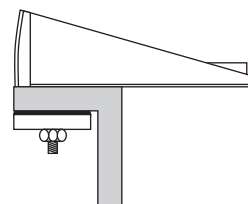

Side Wall:

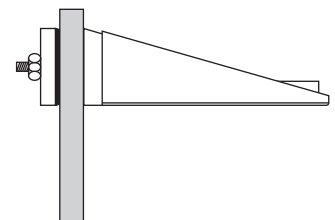

WIRING

Step Four

Wiring:

Each level has a SPDT reed switch rated at 20 VA. The SPDT reed switch enables the switch to be wired either Normally Open or Normally Closed. The normal position for each switch point is typically when the switch is resting on the grip ring. In the illustration below, switch points B and C are in the active or energized position. Switch points D and E are in the normal position. The alarms indicate activity.

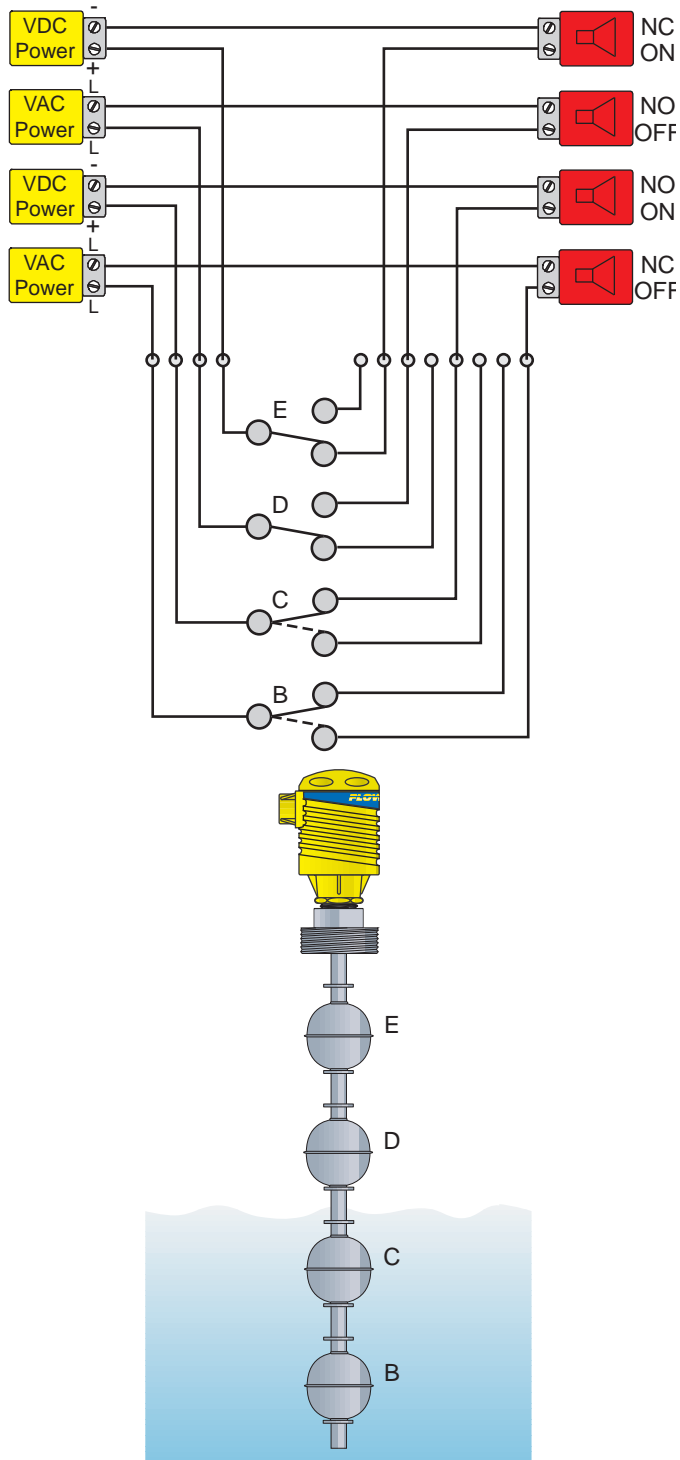

MAINTENANCE

Step Five

General:

The Float-Point level switch has no scheduled maintenance requirement, except to clean off any deposits or scaling from the switch as necessary. It is the responsibility of the user to determine the appropriate maintenance schedule, based on the specific characteristics of the application liquid.

Cleaning procedure:

- 1. Power:** Make sure that all power to the switch, controller and/or power supply is completely disconnected.
- 2. Switch removal:** If necessary, make sure that the tank is drained to a safe level and that the pressure is sufficient for removal of the Float-Point. Carefully, remove the sensor from the installation.
- 3. Cleaning the switch:** Using a soft bristle brush and mild detergent, carefully wash the switch. Do not use harsh abrasives, which might damage the surface of the sensor. Do not use incompatible solvents which may damage the sensor's 316 ss body. Take particular care to remove any scaling from the float body and make sure that it moves freely.
- 4. Sensor installation:** Follow the appropriate steps of installation as outlined in the Installation section of this manual.